

# Expansion relay E1T



## More outputs

By connecting expansion relays to a safety relay it is easy to increase the number of safe outputs. This means that an unlimited number of dangerous machine operations and functions can be stopped from one safety relay.

## Safe soft stop

When a gate is opened a program stop is first given to the machine's PLC/servo which brakes the dangerous operations in a soft and controlled way. The safety outputs then break the power to the motors, that is, when the machine has already stopped. Normally between 0.5 and 1 second is needed to brake a dangerous machine operation softly.

Soft stop ensures many advantages:

- The machine lasts longer.
- Parts being processed are not damaged.
- Restart from stopped position is enabled and simplified.

A safe soft stop is achieved by means of a safety relay which gives the program stop, and an expansion relay, E1T, which gives safe delayed stop signals. See section "Connection examples". The drop time delay on a E1T can as standard be selected from 0 to 3 seconds. By connecting several E1T's in series even longer times can be achieved.

## When are delayed safe stops used?

Delayed safety stop signals can be used for emergency stops according to EN418 § 4.1.5. Stop category 1, i.e. a controlled stop with power to the actuator(s) available to achieve the stop and then removal of power when stop is achieved.

## Approvals:



## Expansion relay with:

- More safety outputs
- Delayed safety outputs
- Output contact indication

## Features:

- Width 22.5 mm
- Supply 24 VDC
- LED output indication
- 4 NO relay outputs
- Single or dual channel operation option
- Quick release connector blocks

Stop category 1 may also be permitted when it is not possible to gain physical access to the machine before the safe stop is affected e.g:

- Gates, access time is normally over 1 sec.
- Covers and gates which are locked until dangerous operations and functions have been stopped.
- Long distances between a safety device and a dangerous machine function.

## Safety level

The E1T has twin stop functions, that is, two relays with mechanically operated contacts. A monitored stop function is achieved by connecting the test output (terminals X1 and X2) to the test or reset input on the safety relay which is being expanded.

One condition for a safe delayed stop is that the delay time cannot increase in the event of a fault. The E1T complies with this requirement.

## Regulations and standards

The E1T is designed and approved in accordance with appropriate standards.

Examples of such are: EN 292-1/2, EN 60204-1, EN 954-1.

## Connection examples

For examples of how our safety relays can solve various safety problems, please see the section "Connection examples".

## Technical data - E1T

Manufacturer:	JOKAB SAFETY AB, Sweden
Ordering data:	E1T+delay time
Colour:	Black and Beige
Operational voltage:	24 VDC +/- 15%
Power consumption:	2W
Relay outputs:	4 NO
Max. switching capacity res. load AC:	6A/250VAC/1500VA
Max. switching capacity res. load DC:	6A/24VDC/150W
Total unit switching cap:	12A distributed on all contacts
Min. switching load:	10 mA/10 V (if load on contact has not exceeded 100 mA)
Maximum external resistance at a nominal voltage:	150 Ohm (S14, S24)
Response time at deactivation (input - output):	<0.015 s, 0.5 s, 1 s, 1.5 s, 2 s, 3 s, ± 20%
Terminals (Max. screw torque 1 Nm):	Single strand: 1x4 mm <sup>2</sup> /2x1,5 mm <sup>2</sup> Conductor with socket contact: 1x2,5 mm <sup>2</sup> /2x1 mm <sup>2</sup> .
Mounting:	35 mm DIN rail
Protection class enclosure/terminals:	IP 40/20 IEC 60529
Operating temperature range:	-10°C - +55°C
Air and creep distance:	4kV/2 IEC 60664-1
Function indication:	output status
Weight:	220 g

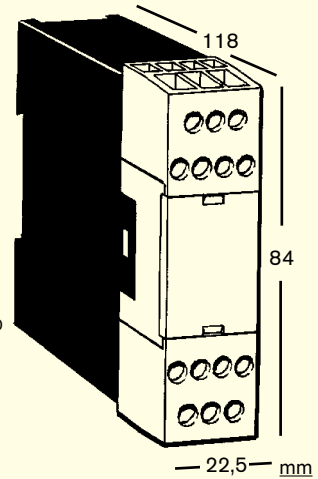

## Technical description - E1T

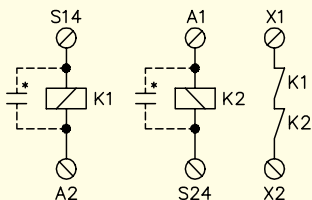

The E1T has to be connected to a safety relay in order to fulfill the necessary safety requirements (see connection examples below). The safety relay controls and monitors the E1T (The E1T can be connected for single or dual channel operation - see below). When the inputs S14 and S24 close, relays K1 and K2 are activated. A stop signal is given, K1 and

K2 drop, if the inputs are opened or during power failure. K1 and K2 drop either directly or after a delay\* (if incorporated). Delay time of module is fixed and shown on front panel of device. The delay circuit is so arranged that the design time cannot be exceeded.

To check that both the relays K1 and K2

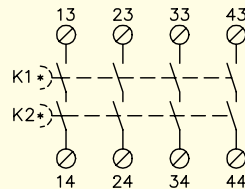

drop during a stop signal they must be monitored. This is achieved by connecting X1 and X2 to the test or reset input on the safety relay which is expanded (see below). K1 and K2 are mechanically operated relays, therefore, if one of the output contacts should stick closed then the relay's contact in X1-X2 cannot be closed thus preventing a new ready signal being given to the safety relay.

Inductive loads should be equipped with an arc suppressor to protect the output contacts.

Diodes are the best arc suppressors but will increase the switch off time of the load.

## Electrical connection - E1T

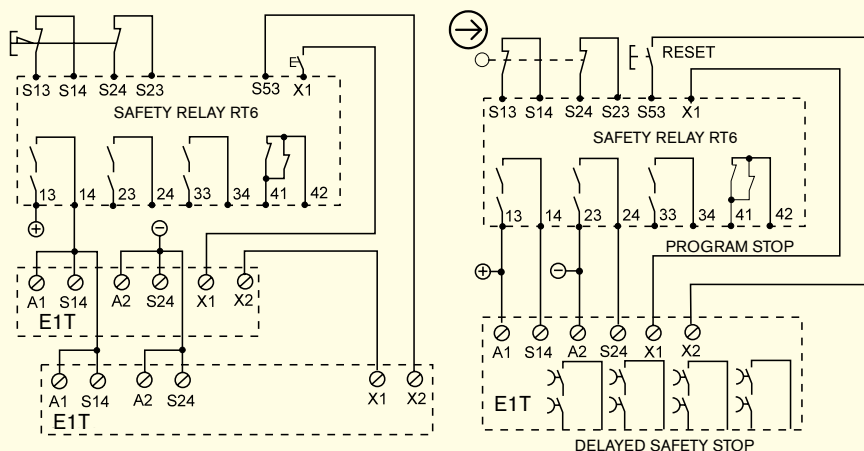

Single channel expansion of outputs for a safety relay connected to an emergency stop.

Dual channel expansion with delayed safety outputs for a safety relay monitoring a gate.