

Three position device

the safest solution during trouble shooting, programming and testing

Approvals:



Why three-positions?

A worker in a dangerous situation must be able to give a stop signal even if he in panic pushes or releases the safety push-button.

Enabling or Hold to Run devices are used during trouble shooting, programming and testing when no other safety devices are practical or possible.

If the worker has to enter a dangerous area to trouble-shoot or to test-drive a machine it is extremely important that he has the possibility to stop the machine without having to rely on someone else standing next to an emergency stop further away. In addition, no-one should be able to start the machine from the outside when the worker has stopped the facility with the three position push button.

Enabling device or Hold to Run control device, what is the difference?

Enabling device: A manually operated device which when continuously activated in one position only, allows hazardous functions but does not initiate them. In any other position, hazardous functions are stopped safely.

Hold to run control device: A manually actuated start and stop device which initiates and maintains operation as long as it is actuated.

The device is ergonomically designed

The device has been ergonomically designed to allow the operation of three different push buttons in one hand. The three position push-button is made using two individual push-buttons under a rubber cover. In this way very weak springs are allowed from the released to the distinct middle position. From the middle to bottom position you have to press against additional springs which are maintaining the distinct middle position. LED's on the device indicate the middle position (green) and the stop positions (red). There are also two additional push-buttons which can be used for initiating machine functions as for example start/stop, forwards/backwards or up/down.

LED's red and green.

Front and top buttons for auxiliary functions.

Dual three-position push buttons give a stop signal when released or pushed to bottom position.



RT9 Safety relay supervises the dual three-position push-buttons and cable.

Three-position devices in different versions



How does a a three position device work?

Safety level

A safe Enabling or Hold to Run device should function as follows:

1. The Stop signal in released (top) and bottom position shall have the same safety level.
2. Provide a 'Start' or 'Ready' signal in a distinct middle position.
3. After a 'Stop' in the bottom position, a 'Start' signal or 'Ready' signal is not permitted until the three position push-buttons have been totally released and again pressed to the middle position. This function is achieved mechanically within the three position push-buttons in the device.
4. A Short or Open circuit in the connection cables shall not lead to a dangerous function e.g. 'Start' or 'Ready' signal.

In order to fulfil the above requirements the three position device must be connected to a suitable dual channel safety relay, e.g. RT6, RT9, JSBT4, which can supervise that both three position push-buttons are working correctly and that there are no short or open circuits in the connection cable or in the device.

Regulations and standards

The JSHD4 is designed and approved in accordance to relevant standards. Examples of relevant standards are EN 292-1/2, EN 60 204, IEC 204, VDE 0110, VDE 0113, BS 2771...

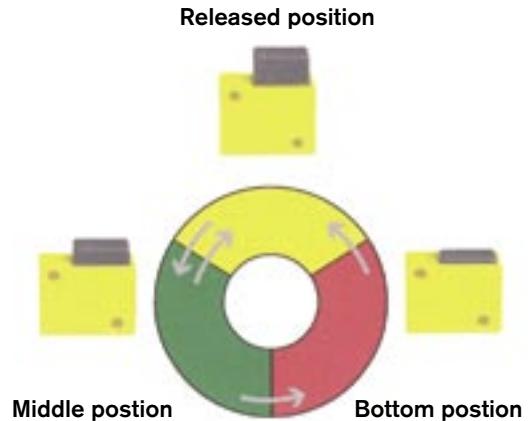

Highest safety level whether the button is pushed or released



When the three position button is released you will obtain a dual stop. It is essential that the machine stops when you put aside the three position device, for example during adjustment.



When the three position button is pushed to the bottom you will obtain a dual stop. It is essential that the machine stops in a panic situation.



Three position device assembled on a machine control unit.



Panel assembly of JSHD4H2 on a programming unit for robots.

Three position device

versions and possibilities

The JSHD4 three position device is readily available in many standard versions. It is also possible to customize the three position device for specific applications.

The three position device can be customized by the selection of the following parts:

- **Front button** - for programme start, low speed, etc.
- **Top button** - for programme stop, grip devices, etc.
- **Bottom plate** - wide bottom plate for fixing interlocking devices and Eden (non-contact sensor) or narrow bottom plate for more agile handling.
- **Bottom connections**
- **Cable**, straight or spiral cable with connectors or assembled on the device
- **LEDs**, alternative connections

Top button

Front button



Bottom plates



Connections



Cables



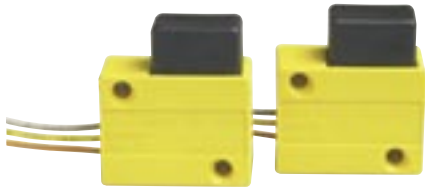

Three position push button JSHD2C

The button is the main component in a safe three-position solution. To achieve the highest safety level two buttons are used in a two-channel system.



Panel assembly JSHD4H2

A panel assembly suitable for building into programming units or similar control boxes. Provides simultaneous activation of both of the three-position buttons.



External assembly JSHD4H2A

The external assembly is similar to the panel assembly unit however it is a 'handle' design making it suitable for assembly on the outside of a control box.



Upgrading kit JSHD4S2

This kit is used to upgrade 'older robot' control systems and will together with a suitable safety relay achieve a safe two-channel three-position function.

Dimensions

JSHD4

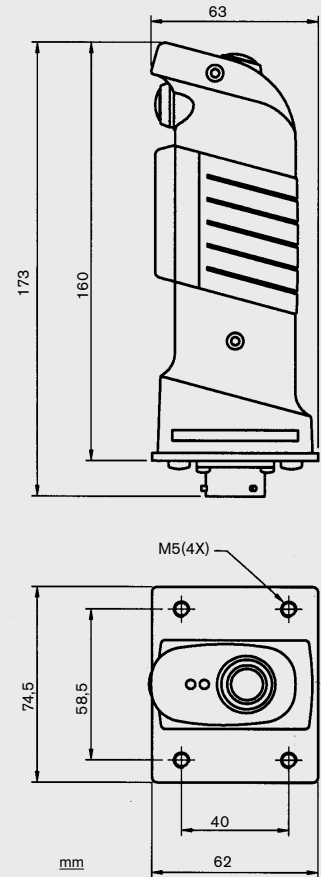

JSHD2C

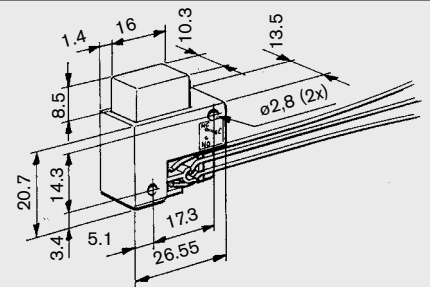

JSHD4H2

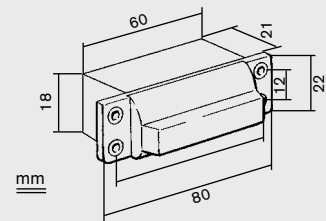

JSHD4H2A

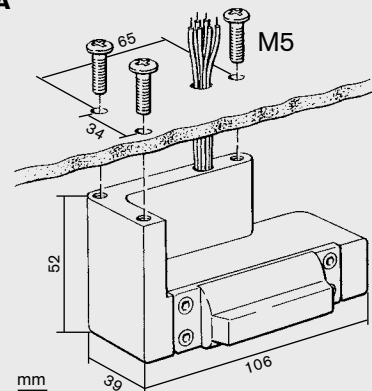

Technical data - JSHD4

Manufacturer	JOKAB SAFETY AB, Sweden	Function indication	Three position buttons ready signal: 'Yes', green LED 'No', red LED
Electrical contact ratings		Material	Polyamid 6.6
Three-position button:	30 VDC, max 0.5 A (min. 10 mA, 10V)	Insulation resistance	min 20 M Ohm
Extra button:	50 VAC/DC max 0.2 A	Operation force	approx. 15 N
Protection class	IP 65	Mechanical life	1 000 000 cycles to middle position
Operating temperature	-10 to +50° C		

Components

Article numbers Description

Standard versions

20-002-00	JSHD4 Three position device with extra buttons (top/front)
20-002-01	JSHD4D Three position device with extra button (front)
20-002-03	JSHD4E Three position device with extra button (top)
20-002-04	JSHD4F Three position device without extra buttons
20-002-37	JSHD4XN Three position device for harsh environments
20-002-74	JSHD4MZ Three position device for Pluto, Safety PLC
20-002-78	JSHD4MU Three position device for Eden
20-002-02	JSHD4H2A Three position device for external panel assembly
20-002-07	JSHD4S2 Three position device, ABB upgrading kit
20-002-31	JSHD4H2 Three position device for internal panel assembly
20-001-10	JSHD2C type E Three position button
20-001-13	JSHD2C type K Three position button

Accessories

20-003-03	JSHK0 12 pole connector
20-003-00	JSHK5 5 Metre cable and connector
20-003-01	JSHK10 10 Metre cable and connector
20-003-02	JSHK15 15 Metre cable and connector
20-003-04	JSHK20 20 Metre cable and connector
20-003-05	JSHK25 25 Metre cable and connector
20-003-10	JSHK5-E 5 metre extension cable
20-003-30	JSHK-T1 Cable drum
20-003-20	JSHK16S 1,6 Metre spiral cable and connector
20-003-21	JSHK20S 2,0 Metre spiral cable and connector
20-003-22	JSHK28S 2,8 Metre spiral cable and connector
20-003-23	JSHK32S 3,2 Metre spiral cable and connector
20-003-24	JSHK40S 4,0 Metre spiral cable and connector
20-003-25	JSHK60S 6,0 Metre spiral cable and connector
20-003-26	JSHK80S 8,0 Metre spiral cable and connector
20-205-28	JSM54A Wallbracket
40-005-03	JSM5A Wallbracket for 2 interlock switches and three position device
40-005-04	JSM52A Wallbracket for three position device



JSHK0 12 pole connector for JSHD4.



Spiral cable, available in different lengths.



Cable, available in different lengths.



Cable drum



JSM5A Wallbracket for interlock switches and three position device.

JSM52A Wallbracket for three position device.

NOTE! Contact us for other variants.

Connection example - Three position device JSHD4 to Pluto

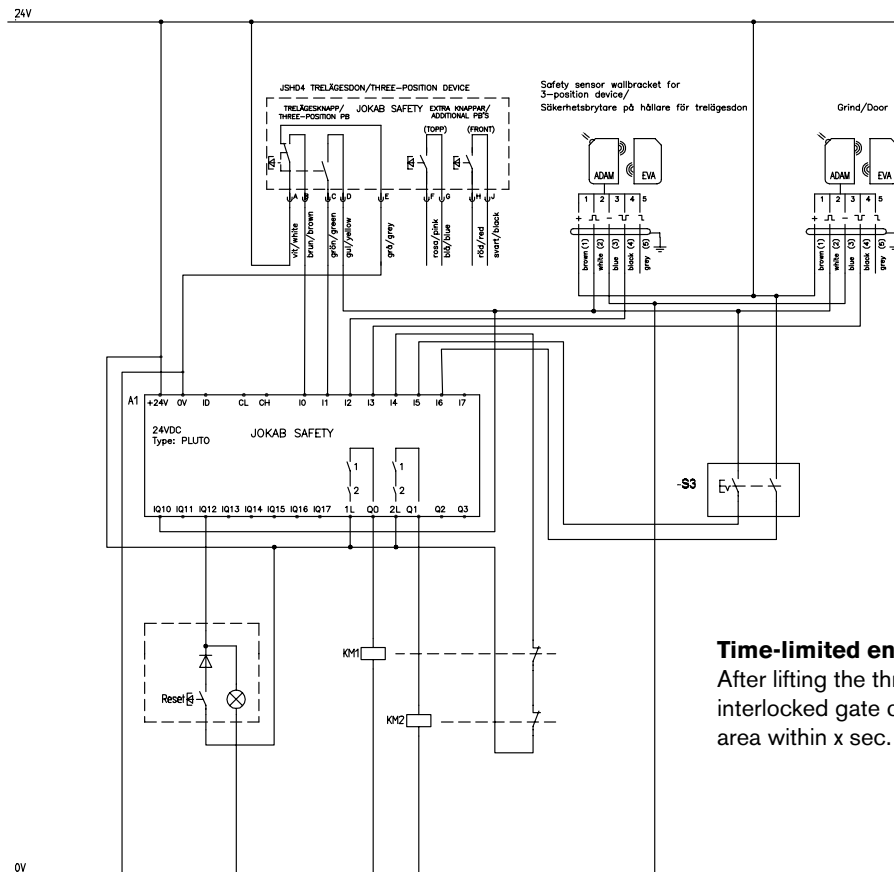

Time-limited entrance/exit
 After lifting the three-position device out of its holder the interlocked gate can be crossed for entrance to the risk area within x sec. The time limit is set in the Pluto program.

Connection examples - Three position device JSHD4 with various safety modules

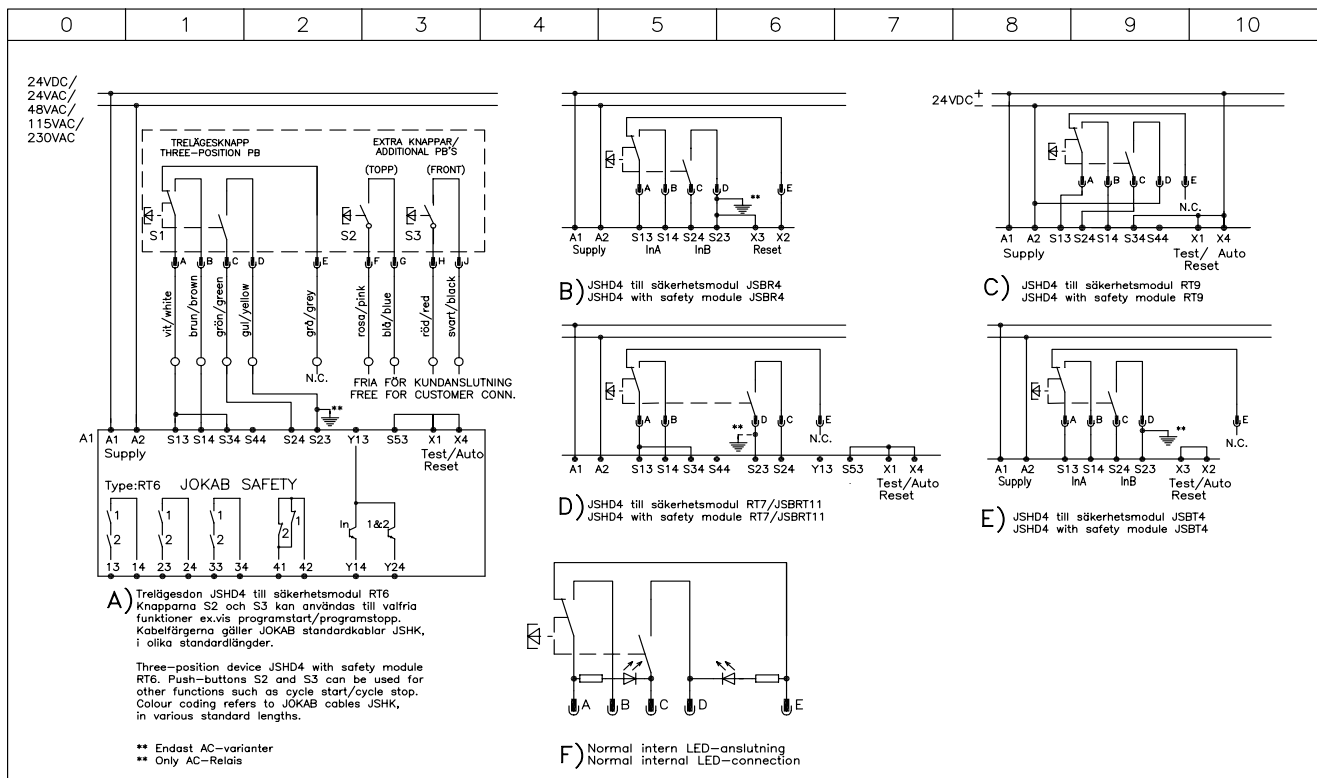

<p>Anmärkning Remark</p> <p>TRELÄGESDON JSHD4 TILL OLIKA SÄKERHETSMODULER THREE-POSITION DEVICE JSHD4 WITH VARIOUS SAFETY MODULES</p>	<p>SWEDEN</p>	<p>Konstr DesignCodk Appr Datum Date</p> <p>JS JS 050112</p> <p>Ritad Drawn Sidor Pages Ritn nr Drawing no</p> <p>JS 1 HH0000C</p>	<p>Blad Sheet</p> <p>1</p> <p>Forts Cont</p> <p>-</p>
---	---------------	--	---

It is the user's responsibility to ensure that all control devices are correctly installed, cared for and operated to meet all applicable European, national and local codes/regulations. Specifications subject to change without notice.