

FEATURES

1. Fully enclosed

All vibrator housings are totally enclosed and are suited for use in dusty environment which meet the requirements of the IP-55, International Protection Standards.

2. Wide selection

Vibrators in 2 to 8 pole are available in 100 models including 50 standard models, permitting wide applications.

3. Antivibration construction

Antivibration devices developed exclusively for use in our vibrators—such as ductile iron casting for the bracket, special compound for the terminal box, and antivibration cable for the cable—have been applied to ensure long service life.

4. Long service life, easy maintenance

Even though the bearings are subjected to severe impacts, URAS vibrators provide a long service life if operated and lubricated properly—more than 5,000 hours for 2-pole models and 10,000 hours for 4- and above models. Moreover, the smaller capacity models are closed type so eliminating the need of lubrication. In medium and large capacity models the periodical lubrication can be carried out from outside.

5. Powerful vibration

Large-capacity machines use roller bearing which are highly resistant to vibration. Moreover, medium-capacity models have adopted a plastic retainer having a superior antivibration characteristics. Hence, powerful vibrations are generated.

6. Reduced weight, free installation direction

When modified exclusively for 60Hz district a reduction of 20% in weight can be expected in large-capacity models.

The adoption of new antivibration bearing facilitates installation of all models.

7. Easy adjustment of forces

Vibratory force can be set easily and steplessly by adjusting the unbalanced weights.

8. Quiet operation

Unlike the electromagnetic type, which produces impact noise, URAS vibrators are of the rotary type and generate no annoying noise.

TYPE/RANGE OF MANUFACTURE

○ Range of Manufacture

Type	No. of poles (P)	No. of types	Capacity (kW)	Vibratory force(kN)
KEE Standard type	2	10	40(W)~3.0	0.5~40
	4	12	65(W)~7.5	1.5~110
	6	15	0.2~18	3~250
	8	11	0.4~15	5~240
KZE Safe improved explosion-proof type	2	5	75(W)~0.75	1~10
	4	8	0.13~2.2	3~52
	6	9	0.2~3.7	3~60
	8	4	0.75~3.7	10~54

Type	No. of poles (P)	No. of types	Capacity (kW)	Vibratory force(kN)
Single phase SEE	2	6	15(W)~0.35	0.1~6
Standard vertical type KEEV	2	5	0.2~1.2	2.4 11.5 5.5
	4	5	0.2~1.2	3 3.5 6.5
	6	5	0.2~1.2	3.6 14.8 7.2

Other types include KDE dust explosionproof types, KHE high frequency types, KZEV factory safety insured explosionproof vertical types, KFE pendulum types and KWE submersible types plus ones having 12 poles.

these are available in 200V and 400V range. URAS vibrators based on a special specifications can also be manufactured and supplied promptly on request.

SPECIFICATIONS, DIMENSIONS AND MAIN APPLICATIONS

■ Three-phase, fixed type. 2 pole

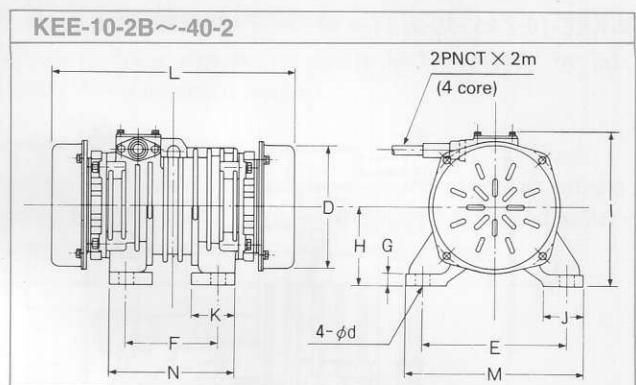
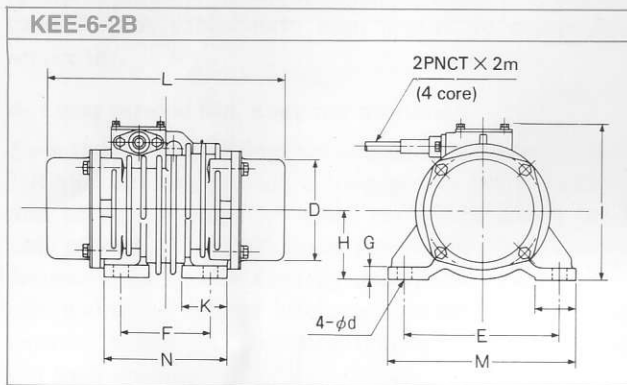
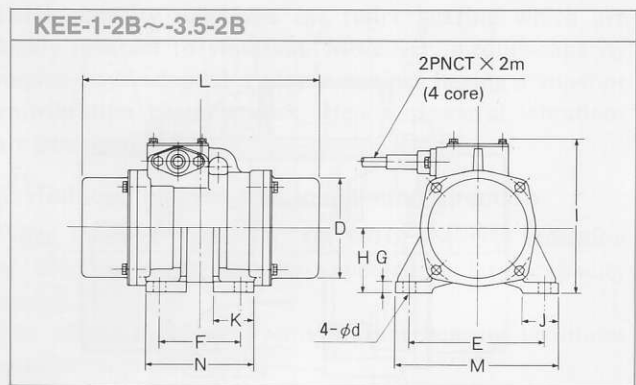
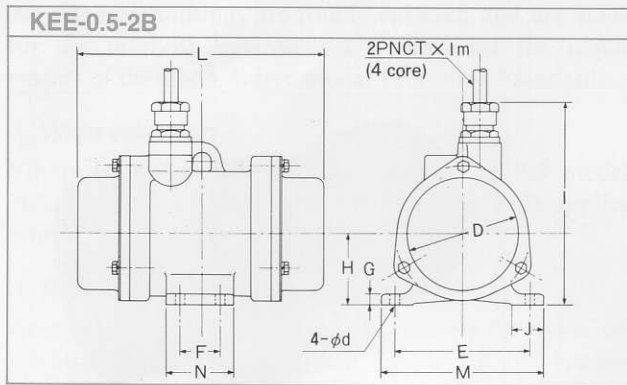

Main applications:

- Hoppers (to prevent discharge difficulties)
- Moulding machines including concrete
- Vibrating feeders
(small-capacity resonance vibration type)
- Paper joggers
- Vibrating tables

URAS Vibrators are most frequently applied to hoppers in order to prevent their discharge difficulties. They are also highly estimated in the field of small-capacity vibration applying machines, for their dependable operations and low noise.

For the method of installing in the hoppers please refer to pages 10 and 11.



Continuous ratings: Three phase, 415V, 50Hz

Type	Vibratory force (kN)	Output (kW)	Full-load current (A) 50Hz	Dimension (mm)													Mass (kg)
				D	E	F	G	H	I	J	K	L	M	N	d	Bolt dia.	
KEE- 0.5-2B	0.5	40W	0.10	85	100	30	8	52	150	23	—	185	120	50	7	M 6	4.5
KEE- 1-2B	1	75W	0.30	90	120	40	9	56	145	35	—	205	145	65	10	M 8	7.5
KEE- 2-2B	2	0.15	0.42	105	130	80	10	62	160	37	40	215	160	110	12	M 10	9.5
KEE- 3.5-2B	3.5	0.25	0.62	110	150	90	12	71	175	40	45	265	180	120	14	M 12	14
KEE- 6-2B	6	0.4	0.90	125	190	110	15	84	195	50	55	300	230	150	18	M 16	22
KEE- 10-2B	10	0.75	1.4	170	220	120	18	92	210	60	65	350	270	170	22	M 20	35
KEE- 16-2	16	1.2	2.4	170	240	140	22	130	260	70	75	420	300	200	26	M 24	52
KEE- 23-2	23	1.7	3.5	190	260	150	22	142	280	70	80	450	320	210	26	M 24	64
KEE- 30-2	30	2.2	4.2	225	310	170	28	158	320	85	95	500	380	240	33	M 30	92
KEE- 40-2	40	3.0	5.7	225	350	220	33	185	360	100	—	560	430	300	39	M 36	135

SPECIFICATIONS, DIMENSIONS AND MAIN APPLICATIONS

■ Three-phase 4 pole

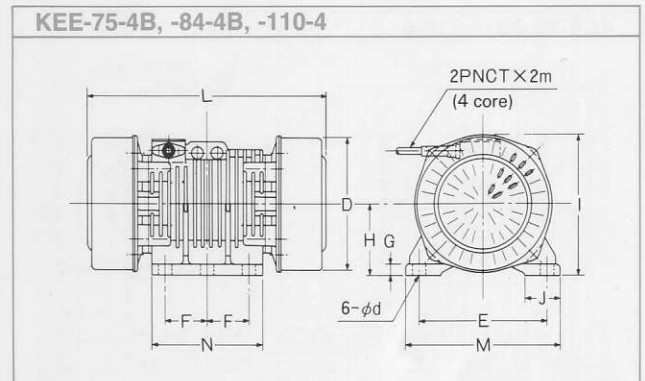
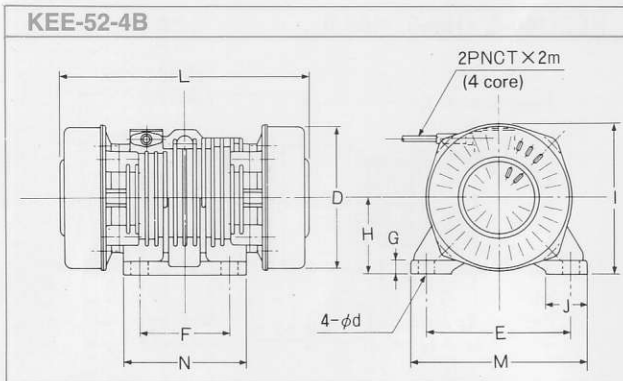
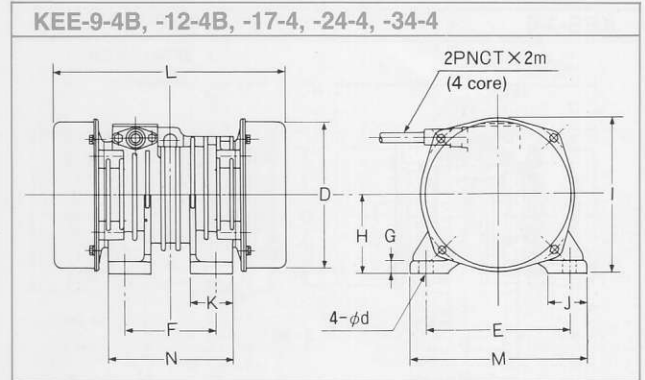
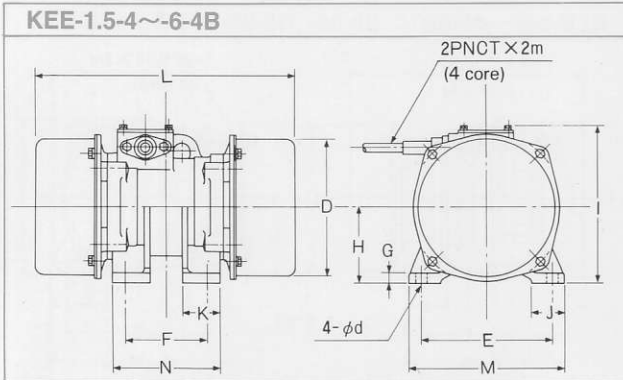

Main applications:

- Concrete hoppers (vibrating plate type)
- Vibrating feeders (medium capacity)
- Vibrating conveyors
- Vibrating hoppers
- Vibrating screens
- Vibrating tables
- Vibrating crushers (small-capacity models)

These types are most popular vibration sources for a variety of vibration applying machines. They are also highly estimated in fields other than above.

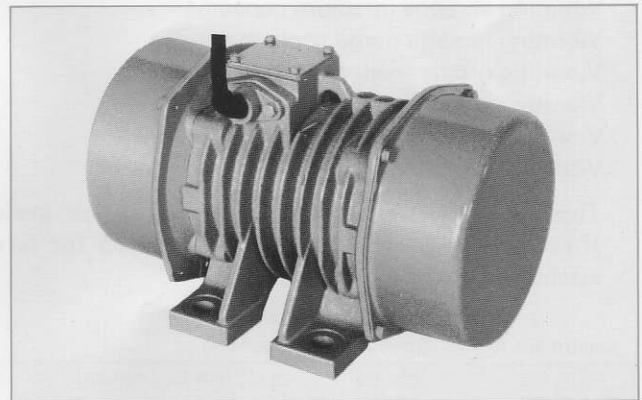

Continuous ratings: Three phase, 415V, 50Hz

Type	Vibratory force (kN)	Output (kW)	Full-load current (A) 50Hz	Dimension (mm)														Mass (kg)
				D	E	F	G	H	I	J	K	L	M	N	d	Bolt dia.		
KEE- 1.5-4	1.5	65W	0.3	135	120	80	9	75	165	30	38	230	145	105	10	M 8	11	
KEE- 3-4B	3	0.13	0.52	155	150	80	10	84	180	35	40	270	180	110	12	M 10	17	
KEE- 6-4B	6	0.25	0.72	170	160	100	12	92	195	40	45	320	190	130	14	M 12	24	
KEE- 9-4B	9	0.4	1.1	190	180	110	15	102	210	50	55	340	220	150	18	M 16	34	
KEE- 12-4B	12	0.6	1.4	225	220	140	18	120	240	60	65	360	270	190	22	M 20	46	
KEE- 17-4	17	0.85	1.9	245	240	140	22	130	260	70	75	420	300	200	26	M 24	62	
KEE- 24-4	24	1.1	2.5	265	260	150	22	142	280	70	80	480	320	210	26	M 24	84	
KEE- 34-4	34	1.5	3.1	295	310	170	28	158	320	85	95	530	380	240	33	M 30	122	
KEE- 52-4B	52	2.2	4.1	345	350	220	33	185	365	100	—	590	430	300	39	M 36	180	
KEE- 75-4B	75	3.7	7.3	395	380	125	33	210	415	105	—	630	460	330	39	M 36	245	
KEE- 84-4B	84	5.5	10.8	395	380	125	33	210	415	105	—	670	460	330	39	M 36	270	
KEE- 110-4	110	7.5	13.9	465	440	140	38	240	475	125	—	730	530	370	45	M 42	395	